



MION es una línea de juegos de diseño atemporal inspirado en la escultura vanguardista. Son estructuras de juego amplias para adolescentes que ofrecen un grado más de emoción y diversión.

MION is a Playground line of timeless design inspired in cutting edge sculptures. These are wide ranging play structures for teenagers that offer a higher degree of emotions and fun

MION est une ligne de jeux de design novateur inspiré par la sculpture avant-gardiste. Des structures de jeux spacieux pour adolescents qui offrent un plus grand degré d'émotion et d'amusement.

MION ist eine neue Spielplatzlinie von zeitlosem Design, die im avantgardistischen Skulpturen inspiriert wurde. Es bieten sich umfangreiche Spiel-Strukturen für Teenager die ein höheren Mass an Spielvergnügen anbieten und so den Spassfaktor steigen lassen.



8 -16



16 m²



3



0,7 m.



Visita nuestra web para más información

Visit our website for more information

Pour plus d'informations visitez notre site web

Besuchen Sie unsere Webseite für mehr Infos

Altura libre de caída / Área de seguridad
Free fall height / Safety area
Hauter libre de chute / Zone de sécurité
Freie Fallhöhe/ Sicherheits- Schutzbereich

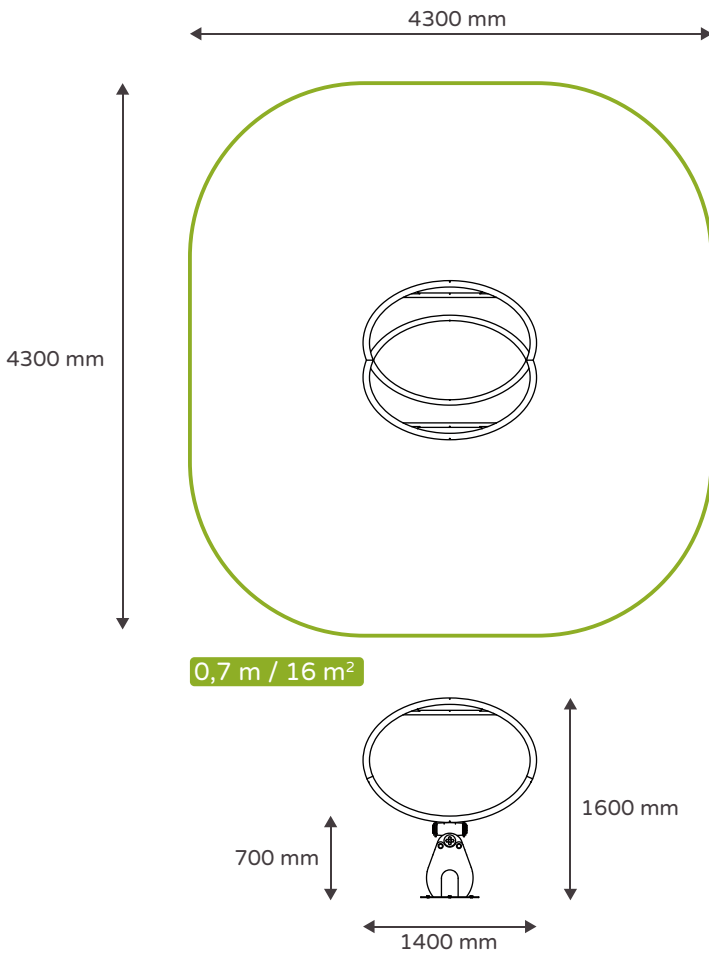

8-16

Edad recomendada
Recommended age
Âge recommandé
Empfohlene Altersgruppe

3

Usuarios recomendados
Recommended users
Usagers recommandés
Empfohlene Kinderanzahl

16 m²

Área de seguridad
Safety area
Zone de sécurité
Sicherheits- Schutzbereich

1,4x1,3x1,6 m

Dimensiones producto
Product dimensions
Dimensions produit
Produkt- Masse

4,3x4,3 m

Dimensiones área seguridad
Safety area dimension
Dimensions zone de sécurité
Sicherheits- Schutzbereich Masse

1h/1

Tiempo montaje / Personas
Assembly time / People
Temps montage / Personnes
Aufbauzeit / Personen

0,7 m

Altura libre de caída
Free fall height
Hauter de chute libre
Freie Fallhöhe

Z2 035376 0043

Certificado TÜV EN-1176
Certificate TÜV EN-1176
Certificat TÜV EN-1176
Zertifikat TÜV EN-1176

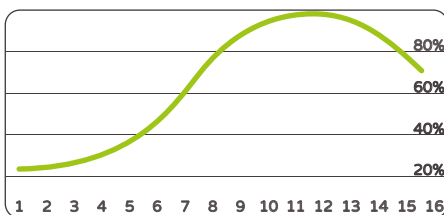
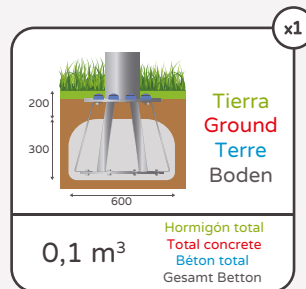
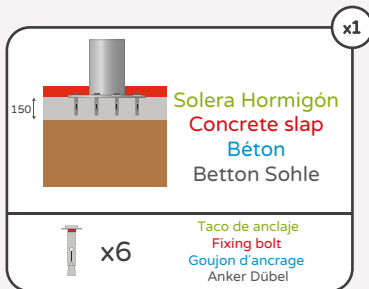

Adecuación/Edad Adequate/Age
Adaptation/Âge Eignung/Alter

Físico/Physic/Physique/Körperlich	<input checked="" type="checkbox"/>	<input checked="" type="checkbox"/>	<input checked="" type="checkbox"/>	<input checked="" type="checkbox"/>
Social/Social/Social/Sozial	<input checked="" type="checkbox"/>	<input checked="" type="checkbox"/>	<input checked="" type="checkbox"/>	<input checked="" type="checkbox"/>
Aprendizaje/Learning/Apprentissage/Lehre	<input checked="" type="checkbox"/>	<input checked="" type="checkbox"/>	<input checked="" type="checkbox"/>	<input checked="" type="checkbox"/>
Creatividad/Creativity/Créativité/Kreativität	<input checked="" type="checkbox"/>	<input checked="" type="checkbox"/>	<input checked="" type="checkbox"/>	<input checked="" type="checkbox"/>

Aptitudes desarrolladas Developed abilities
Aptitudes développées Entwickelte Fähigkeiten

Metal/Metal/Métal/Metall	92 %
Plástico/Plastic/Plastique/Plastik	- %
Otros/Others/Autres/Andere	8 %
Reciclabilidad/Recycling/Recyclabilité/Recycling	75 %

Material y Reciclabilidad Material and Recycling
Matériel et Recyclabilité Material und Recycling

*Disponibilidad de repuestos durante 12 años. Sumalim tiene el derecho a poder modificar los colores y diseño de los elementos descritos en este documento sin previo aviso.

*Spare parts availability for 12 years. Sumalim has the right to change the colours and design of the described elements in this document, without previous notice.

*Disponibilité de pièces de rechange pendant 12 ans. Sumalim se réserve le droit de modifier les couleurs et le dessin des éléments décrits dans ce document sans préavis.

*Die Verfügung von Ersatzteilen ist 12 Jahre. Sumalim hat das Recht die Farben und das Design von denen in diesen Dokument beschriebenen Elementen, ohne vorheriger Ankündigung, zu verändern.

Elemento balanceante de flector (4 sentidos)

Balance seesaw with rubber suspension system (4 ways)

Élément oscillant de suspension en caoutchouc (4 sens)

Gummifeder Wippgerät (4 Richtungen)

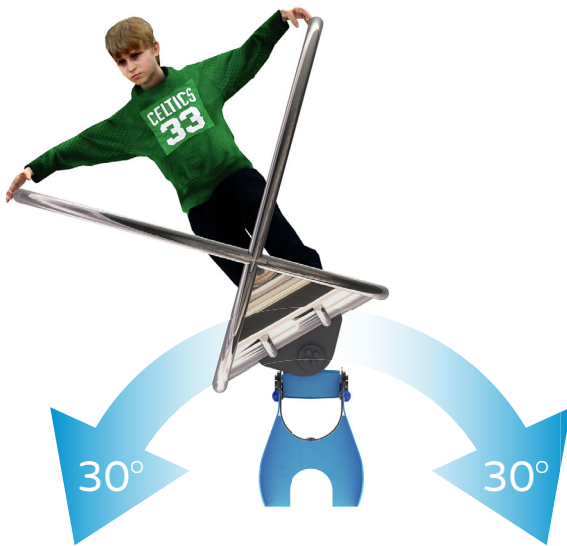

- Barras (Ø50) de acero galvanizado (según normativa UNE-ISO 1461/99) o acero inoxidable AISI 316L
- Soporte en acero con recubrimiento termoplástico PPA 571 de espesor 400 µ
- Suelo de plataforma curvada en EPDM de color
- Tornillería con tratamiento JS-500 de más de 8µ o acero inoxidable

- Bars (50Ø) of galvanized steel (according to the UNE-ISO 1461/99 regulation) or stainless steel AISI 316L
- Steel holder with thermoplastic coating PPA 571 of 400 µ thickness
- Curved platform flooring in coloured EPDM
- JS-500 treated bolts with more than 8 µ or stainless steel bolts

- Barres (Ø50) en acier galvanisé (par normative UNE-ISO 1461/99) ou acier inoxydable AISI 316L
- Support en acier avec revêtement thermoplastique PPA 571 épaisseur 400 µ
- Revêtement plateforme courbée en EPDM de couleur
- Visserie avec traitement JS-500 de plus de 8µ ou en inoxydable

- Stangen (Ø50) aus feuerverzinktem Stahl (gemaess UNE-ISO 1461/99 Norm) oder aus Edelstahl AISI 316L
- Stahhalter mit PPA 571 Waerme Kunststoff Beschichtung und Dicke 400 µ
- Boden aud runder Platform in farbiges EPDM
- Schrauben mit JS-500 Behandlung von mehr als 8 µ oder Edelstahl Schrauben

100 Kg

Peso total
Total weight
Poids total

Gesamt Gewicht

1400x1300x1600 mm / 100 Kg

Pieza más pesada
Heaviest piece
Pièce plus lourde

Gewicht des schwersten Teiles

1400x1300x1600 mm / 100 Kg

Pieza más grande
Biggest piece
Pièce plus grande

Groesstes Teil



SUMALIM
PLAYGROUNDS

CARRETERA DE URROZ, KM 1 | E-31398 TIEBAS (NAVARRA) SPAIN
+34 948 311511 | info@sumalim.com | www.sumalim.com



